

AVIV MODEL 62DS CIRCULAR DICHROISM SPECTROMETER INSTRUCTION MANUAL

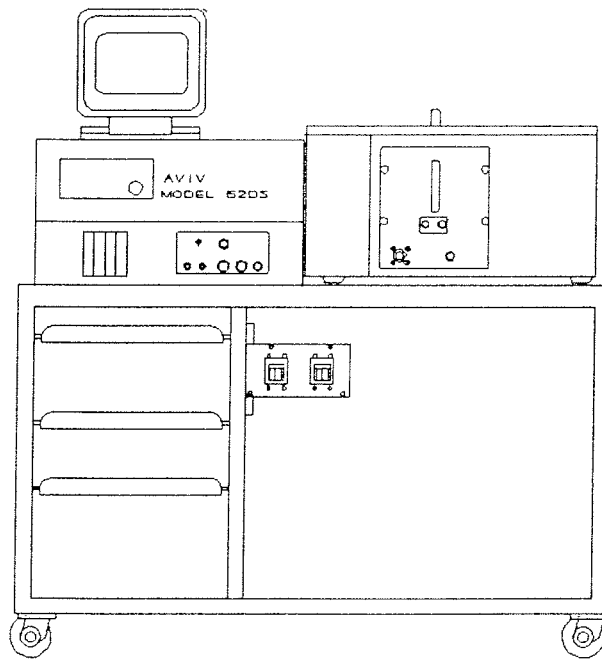

Aviv Associates, Inc.
750 Vassar Avenue
Lakewood NJ 08701
PHONE (908) 367-1663 TECH SUPPORT-Guy McCaffery
FAX (908) 370-0032

copyright 1989
manual version - 1.0.4a
revision date - 16-Jun-1989

ORIGINAL INSTRUMENT WARRANTY PERIOD:

One year from date of shipment.

ORIGINAL INSTRUMENT WARRANTY:

This warranty covers Instruments and Instrument Systems sold by AVIV Associates ("hereinafter called SELLER") to individuals, groups, academic institutions, governmental organizations or corporations ("hereinafter called CUSTOMER"). SELLER warrants each item manufactured by the SELLER or provided as a component of an Instrument System to be free from defects in material and workmanship for a period of one year. Liability under valid warranty claims is limited to repair, replacement, or refund of an equitable portion of the purchase price of the Product, all at the option of SELLER. This warranty is expressly in lieu of all other obligations or liabilities on the part of SELLER unless such other obligations or liabilities are agreed to in writing by SELLER. Any special warranty extension shall be in accordance with and upon the conditions set forth in the warranty for the individual Product. This warranty expressly excludes items that are generally considered to be consumable or disposable. Such items as paper, ribbons, Xenon lamps, Deuterium lamps, Tungsten lamps, and cells fall into the consumable or disposable category. Intentional instrument abuse or negligence on the part of the CUSTOMER can void part or all of any remaining warranty. Such acts as mishandling of photomultiplier tubes voids the warranty on the individual component. However, running Instruments with Xenon lamps without Nitrogen or cooling water voids the entire warranty. SELLER assumes no liability for Instrument damages resulting from CUSTOMER installed Instrument modifications that are not provided by SELLER. Nor is SELLER obligated to repair any such CUSTOMER modification under this warranty.

WARRANTY REPLACEMENT AND ADJUSTMENT:

All claims under warranty must be made promptly after occurrence of circumstances giving rise thereto, must be received within the applicable warranty period by SELLER or its authorized representative, and shall be subject to the terms and conditions stated herein. Such claims should include the product serial number, date of shipment, and a full description of the circumstances giving rise to the claim. Before any Products are returned for repair and/or adjustment, a RETURN AUTHORIZATION number (RA) will be given for the return, and instructions as to how and where these Products should be shipped. Any product returned to SELLER for examination shall be sent prepaid via the means of transportation indicated as acceptable by SELLER. SELLER reserves the right to reject any warranty claim on any item that has been shipped by non-acceptable means of transportation. When any Product is returned for examination and inspection, or for any other reason, CUSTOMER and CUSTOMER's shipping agency shall be responsible for all damage resulting from improper packing or handling, and for loss in transit, notwithstanding any defect or nonconformity in the Product. In all cases SELLER has sole responsibility for determining the cause and nature of failure, and SELLER's determination with regard thereto shall be final. If it is found that SELLER's Product has been returned without cause and is still serviceable, CUSTOMER will be notified and the Product returned at CUSTOMER's expense; in addition, a charge for testing and examination may be made at the SELLER's sole discretion.

TABLE OF CONTENTS

Section	Page
List of Figures	v
List of Tables	vi
List of Text Boxes	vii
1 General Description and Specifications	1
1.1 Introduction	1
1.2 Optical System	1
1.2.1 Xe Lamp Compartment	1
1.2.2 Monochromator	2
1.2.3 Polarizer Compartment	3
1.2.4 Sample Compartment	4
1.2.5 Detector Compartment	4
1.3 Electronics	4
1.4 Computer System and Software	5
1.4.1 Computer System	5
1.4.2 Program Startup	6
1.5 Standard Options	9
1.5.1 Temperature Control Systems	9
1.5.2 Advanced Data System Accessories	9
1.5.3 Plotters	10
1.5.4 Miscellaneous Accessories	10
2 Installation	13
2.1 Installation requirements	13
2.1.1 Electrical Power Requirements	13
2.1.2 Environmental Requirements	13
2.1.3 Instrument Water Requirements	14
2.1.4 Instrument Nitrogen Requirements	14
2.2 Instrument Dimensions and utility layout	15
2.3 Installation and Setup	16
2.3.1 Instrument	16
2.3.2 Computer and peripherals	16
2.3.3 Software Installation	16
3 Instrument Operation	17
3.1 System Startup	17
3.2 Normal Operation	17
3.3 System Shutdown	18
4 Sample Handling	19

4.1 Sample compartment	19
4.2 Cells in the CD	19
4.3 Using cylindrical cells	19
4.4 Sample preparation	20
4.4.1 Optimizing Conditions	20
4.4.2 Use the same cell for the baseline	20
4.5 Care and cleaning of cells	20
4.6 Temperature Control	20
5 Maintenance	23
5.1 Introduction	23
5.2 Instrument Calibration Procedures	23
5.2.1 Wavelength Calibration	23
5.2.2 CSA checks	24
5.2.3 Energy tests	27
5.2.4 Noise	28
5.3 Error Flags and problems	29
5.4 Lamp Changing	29
5.4.1 Warnings and Precautions when changing Xenon Lamp	29
5.4.2 Lamp removal	29
5.4.3 Lamp and compartment Inspection	30
5.4.4 Lamp Installation	30
5.4.5 Lamp optimization	30
5.5 Calibrating options	31
5.5.1 Thermometer Calibration.	31
5.5.2 Bath Calibration	32
6 Appendix	34

List of Figures

Figure 1 Arrangement of Optical Elements in AVIV 62DS	2
Figure 2 Instrument Dimensions and Utility Layout	15

List of Tables

Table 1 Key to Optical Elements of AVIV 62DS	2
Table 2 Specifications for 62DS	12
Table 3 Current in Amps used by Instrument and Options	13

List of Text Boxes

Text Box 1 Text of Auto60.bat	6
Text Box 2 Text of Autoexec.avi	8

Section 1 General Description and Specifications

1.1 Introduction

The AVIV 62DS is a spectrometer for precise automatic recording of circular dichroism (CD) spectra. Care has gone into the design and construction of the 62DS to make it the premier CD instrument in the world.

The 62DS can functionally be divided up into several subsystems: the optical system, the electronics, external power supplies and the computer with software. The optical system is farther divided into 5 subsystems based on their location and function in the instrument: 1) light source compartment, 2) monochromator, 3) polarizer compartment, 4) sample compartment, 5) detector compartment. Figure 1 is an optical diagram for the 62DS, the optical elements in Figure 1 are identified in Table 1. The external power supplies for the Xenon light source rounds out the basic 62DS instrument.

Each subsystem is required for proper operation of the instrument. A detailed description of each subsystem is included in this section to acquaint the operator with the instrument.

1.2 Optical System

1.2.1 Xe Lamp Compartment

The light source is a 450 watt Xenon arc lamp, which has a Suprasil envelope which transmits well into the UV. The lamp is controlled by a high stability, constant current, DC power supply. The lamp is held in place by a mount which provides for three axis alignment of the lamp. Lamp adjustment is discussed in the Maintenance section.

The light from the Xe lamp is collected by an ellipsoidal mirror which focuses an image of the arc on the monochromator entrance slits. The image is magnified 8 to 10 times, so that the arc image fills the entrance slits. The light between the ellipsoidal mirror and the entrance slits is folded by means of a flat mirror to decrease the working space and increase the optical path. Cooling coils in the lamp house dissipate the heat generated by the lamp.

Table 1 Key to Optical Elements of AVIV 62DS

A	Xenon arc Lamp	H	Collimator
B	Ellipsoidal mirror	P2	Second Prism
C	Flat mirror	S3	Exit Slit
S1	Entrance slit	I	Achromatic Triplet Lens
E	Collimator mirror	LP	Linear Polarizer
F	Flat mirror	M1	Extraordinary Beam Mask
P1	First Prism	PEM	Photoelastic Modulator
S2	Intermediate Slit	SC	Sample Cell
G	Flat mirror	PM	Photomultiplier Tube

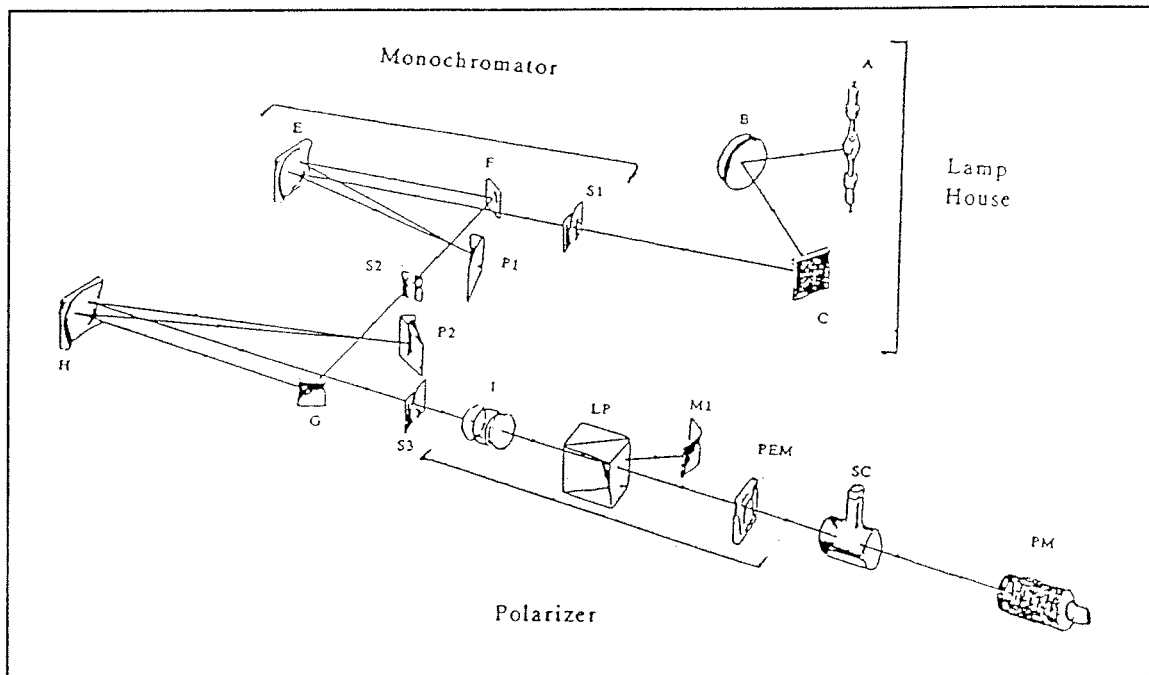

Figure 1 Arrangement of Optical Elements in AVIV 62DS

1.2.2 Monochromator

The white light produced by the Xe lamp is dispersed by the monochromator. The monochromator is actually two fused silica prism monochromators in series. This double monochromator design produces better wavelength resolution and has less stray light than a single monochromator. The prisms provide excellent dispersion of

light in the UV. The monochromator has a wavelength range of 175 nm to 800 nm.

The two prisms are connected by a linkage to a wavelength cam. The cam converts the non-linear dispersion of the quartz prisms into linear motion of the external gear drive mechanism. The gear drive is moved by a computer controlled stepper motor. The speed of this motor is approximately 5 nm per second. Each motor step corresponds to a 0.01 nm change in wavelength. This step size sets the limit to which the wavelength can be specified.

The monochromator drive mechanism is designed to be accurate only when moving from longer to shorter wavelengths. When the program moves the mechanism from a shorter to a longer wavelength, it always overshoots by 10 nm and then moves back, in order to eliminate the backlash in the drive mechanism and restore accuracy.

The linear wavelength scale means that only one point needs to be specified for wavelength calibration. This calibration wavelength corresponds to the position of an optical beam switch linked to the motion of the wavelength cam. The program finds the switch position at startup and associates this position with a calibration wavelength obtained from a disk file. All other wavelengths are determined by counting steps from this point. Wavelength calibration is discussed in detail in the Section on Maintenance.

The monochromator has three sets of sharp edge slits: entrance slits, intermediate slits (between monochromators) and exit slits. The 3 monochromator slits all move synchronously under the control of an external drive system. The width of the slit opening selects the portion of the spectrum sent to the sample. A potentiometer on the drive is sampled by the electronics to sense the slit position. The potentiometer voltage is converted to width and is displayed on the control screen.

A stepping motor is used to move the slits to the desired width. The maximum slit opening of 3 mm corresponds to different spectral bandwidths at different wavelengths. In normal constant-bandwidth operation the program converts the desired spectral bandwidth to a slit width using a stored version of the monochromator dispersion function. While the constant-bandwidth mode reminder (B before the slitwidth) is on, the slitwidth shown is the desired width. While the actual slitwidth is different from the target, the program will try to move the slits to make them agree with the target value. When the B is turned off, the slitwidth display shows the actual value and the program will not try spontaneously to move the slits.

1.2.3 Polarizer Compartment

An achromatic lens is used to focus the monochromatic light from the monochromator exit slit into the sample space. The achromat design focuses the light in the same location independent of wavelength.

The light is linearly polarized by a MgF_2 polarizer. The polarizer creates two light beams; only the ordinary beam is used in the CD measurement. The extra-ordinary beam is removed by a mask after the modulator.

The linearly polarized light is passed through a modulator plate. The plate is driven by a 50 KHz oscillator to produce a strain-induced birefringence which is oriented at 45 degrees to the axis of the linearly polarized light. The amplitude of the oscillation is controlled so that the strain plate alternately produces +90 and -90 degrees retardation along one birefringent axis at the oscillation peaks. Thus the light becomes alternately, left and right circularly polarized.

1.2.4 Sample Compartment

The sample compartment has been designed to be large enough to accommodate a variety of accessories. The sample compartment has access through the top, front and bottom. The front access is through a removable door/shelf combination. The bottom access hole allows use of the BioLogic stopped flow unit. Two optional temperature control systems fit inside the sample space and allow data collection over a wide temperature range. As the light beam is focused on the sample cell, micro cells can be used without special accessories.

1.2.5 Detector Compartment

Light is detected by a high speed, high sensitivity, end-on photomultiplier tube (PMT). A preamplifier in the PMT housing converts the tube output current to a voltage which is sent to the electronics for processing.

The PMT is normally operated in a constant current mode. The applied dynode voltage is varied by the software as necessary to keep the tube current constant as the light input changes. Should the software fail to update the dynode voltage setting in a timely manner, the hardware will shut off the high voltage.

Dynode voltages for the PMT are produced by a voltage divider chain at the tube socket. The high voltage generator is mounted near the PMT housing. The generator produces about 100 volts for each volt of input it receives from the electronics. The high voltage output is sampled by the electronics and is displayed on the control screen.

1.3 Electronics

The electronics consists of two functional groups: the specialized CD signal processing circuits and a set of general control electronics.

The signal from the PMT is passed through two filters to separate the average

absorbance signal (DC component) and the delta absorbance signal (50 kHz component). The ratio of these two signals is the circular dichroism. The DC component is extracted by a low pass filter. The output of this filter is sampled by the A/D converter in the general electronics and is displayed on the control screen. As mentioned above, the software keeps this signal constant, by adjusting the PMT dynode voltage.

The 50 kHz signal is passed through a high pass filter and then a bandpass filter. A detector synchronized to the modulator converts the 50 kHz signal to DC. The DC output of the synchronous detector is passed through a low pass filter. The output of this low pass filter is also sampled by the electronics and is used along with the DC component to generate the displayed CD signal. CD calibration of the instrument is performed by adjusting the gain of this low pass filter to produce the correct reading with a standard sample.

The general control electronics consists of circuits to generate step signals for the two motors, D/A converters and amplifiers to control the high voltage, the modulator retardation, and the optional bath temperature, and a twelve bit high speed A/D converter which is used in all measurements. A voltage multiplexer before the converter lets the computer select one of eight signals to measure. One channel is unused, one channel is available for user generated signals, one channel is used for temperature, one for slit position, one is used for dynode voltage, one for the PMT DC signal, one for the delta absorbance signal, and one measures the retardation voltage. This last signal is used for self test of the D/A - A/D converter combination.

The general general electronics are connected by a high speed eight bit parallel bus to an interface card in the computer. Timing is primarily derived from the high speed real time clock in the computer. Motor timing is based on 1200 timer interrupts a second. This is divided down to generate slower intervals such as the dynode voltage update rate of 20 per second.

1.4 Computer System and Software

1.4.1 Computer System

The computer system includes the following items: monitor, keyboard, CPU and math coprocessor, 640 Kb RAM, one 360 Kb Floppy, one 20 Mb Hard drive, one parallel port, one parallel printer, one serial port, an optional plotter, AVIV Optics Interface Board, MS-DOS system software, and the instrument programs.

The computer communicates with the instrumental electronics via the AVIV Optics Interface Board. The instrument is controlled by programs which are run on the computer. The operator controls the instrument by means of two different operating systems: direct control from the keyboard, and yhr command system. The command

system allows commands to come from macro files or through the serial port from a remote computer. Data storage in RAM is over 50,000 points (e.g. 200 spectra with 250 points each) as the computer is configured from the factory. Data storage on floppy disks is virtually unlimited. The instrument program has a diverse set of data manipulation routines built in to help analyze data.

The AVIV DS programs are discussed in the Software Manual.

1.4.2 Program Startup

The DOS command "go 60" invokes the batch file go.bat, which passes control to auto60.bat. Auto60.bat is responsible for installing the memory resident parts of the instrument software and for managing the instrument power-on self test. Auto60.bat is reproduced in text box 1.

```
rem - this is auto60.bat
prompt $d $t$_$p $g
path c:\dos;c:\pe2;c:\;..
echo on
if %mr% == 1 goto trygra
set mr=1
rem - the following programs must run exactly once before starting 60ds
oitest
if errorlevel 1 goto exit
timer
multi
motor
if errorlevel 1 goto exit
servo
sample
:trygra
if %gr% == 1 goto tryrun
set gr=1
rem 0 0 oki; 0 1 epson, 0 2 tally (as lpt1)
graphics 0 0
:tryrun
60ds
:exit
```

Text Box 1 Text of Auto60.bat

The environment variables "mr" and "gr" are used to control the loading of the memory resident programs. Since the screen dump program can be loaded either by starting the instrument or by starting the plot program, a separate variable, gr, is used to indicate that the screen dump has been loaded. Both mr and gr are set to zero upon system boot by the autoexec.bat file in the root directory. When the resident programs are loaded, the associated variable is set to 1 so that loading will not be attempted on subsequent go commands.

Poweron self test is performed by the programs oitest.com and motor.com, which are run once as part of the instrument startup process. A failing program returns an errorlevel of 1 instead of zero. The batch file above detects the failure return and skips out of the startup process. Passing these two tests indicates that at least the core of the instrument electronics is working. This knowledge greatly simplifies problem diagnosis.

If a failure should occur, check first that the instrument electronics are powered on, and then reboot the computer to try the startup again. If a test repeatedly fails, you should save the program output and call for help in interpreting the error messages. You can get a printout of the failing startup by setting DOS to copy to the printer everything sent to the screen. Hold the Ctrl key while pressing PrtSc to turn on this mode. Be sure that the printer is on and selected. Repeat the Ctrl-PrtSc to turn printing off again later.

Oitest.com checks the instrument interface data path inside the computer. Once this is known to work motor.com can check the data path into the electronics in the instrument. Once the digital data path is known good, motor.com checks the behavior of the D/A - A/D converter pair on the instrument controller card. If the A/D converter checks good, then erroneous values on the control screen can confidently be interpreted as failures in more peripheral circuits. These failures are extremely rare, but this procedure should result in more rapid diagnosis and correction of those failures that do occur.

Timer.com, motor.com, sample.com, multi.com, and servo.exe are resident programs that perform various parts of the instrument function. The operation of these resident programs is not visible directly at the user level.

Graphics.com performs the graphics screen dumps. It may also be loaded as part of the plot program startup.

60DS.EXE is the main instrument program. This program collects and formats the data and manages the control screen. 60DS is not resident.

Autoexec.avi is the first command file for 60DS. This file contains the startup profile for the instrument program. Autoexec.avi is a plain ASCII file that can be

modified with any convenient editor to accommodate the instrument to the users preferred mode of operation. A complete reference for the commands available is provided as an Appendix. A version of autoexec.avi is shown in text box 2.

```

/* autoexec.avi */
[PATH_LOG,"C:\C60\LOG\"]          /* where log files go */
[OPEN_LOG,"OPERATE.LOG"]         /* start the first log file */
[PATH_COMD,"C:\AVI\"]           /* where command files are located */
[PATH_DATA,"A:\"]              /* where data is stored */
[PATH_HELP,"C:\C60\"]          /* where the help file, keys.lst, is */
[EXECUTE,"C:\AVI\WAVECAL.AVI"] /* set the home wavelength */
[WAVE_ULIM,800]                 /* set hard upper limit */
[WAVE_LLIM,180]                 /* set hard lower limit */
[SET_RIGHT,400]                 /* set screen right limit */
[SET_LEFT,200]                  /* set screen left limit */
[HOME_ALL,"Y"]                  /* home the monochromator */
[SET_TEMP,25]                   /* set bath setpoint */
[REPAINT]                       /* draw the initial screen */
[MAKE_SETUP]                    /* make the first setup file */

```

Text Box 2 Text of Autoexec.avi

The file "c:\avi\wavecal.avi" contains the wavelength calibration value for the monochromator. The program "INST-CAL.EXE" is provided to help maintain wavecal.avi. Inst-cal can be invoked from the DOS prompt. The only mandatory commands in autoexec.avi besides execution of wavecal.avi are [HOME_ALL,"Y"] to home the monochromator, [REPAINT] to draw the initial screen, and [MAKE_SETUP] to create the first instance of the special setup file.

Several other files are normally present in the c:\c60 directory. These include KEYS.LST, and HISTO.EXE.

Keys.lst is the file displayed by the key combination Alt-H [HELP]. The instrument program displays keys.lst a screen (23 lines) at a time. Keys.lst first has a short list of commonly used keys, followed by a complete list of all keys grouped by function. Keys.lst is a plain ASCII file. You may modify this file as needed to present the information you find most helpful.

Histo.exe is a specialized program used to test and calibrate the A/D converter and attached circuits. Histo.exe is present for service use only. Histo can be run anytime after 60ds.exe has run once.

1.5 Standard Options

1.5.1 Temperature Control Systems

Thermometer (0813000001): sealed, miniature, electronic thermometer for display, recording, and control of sample temperature.

Insulated cell holder for water jacketed 22 mm cylindrical cells. (6040026000) It is not recommended to use the silicone fluids with water jacketed cylindrical cells because the silicone fluid absorbs strongly in the far UV and is difficult to remove from surfaces once exposed to a surface.

Bath (0909000001): Data system controlled, circulating fluid bath allows operation over a wide temperature range (-10°C to 90°C). Requires thermometer.

Two types of silicone fluid are available. Regular silicone fluid is used in baths as a high performance temperature control medium. This fluid heats and cools 2.2 times faster than water and does not evaporate or freeze. The super silicone fluid use in is an extra high performance temperature control medium. This fluid is more expensive, but has better low temperature performance than the regular silicone fluid.

Cuvette holder for 10 mm cells (6040022000). A high efficiency thermostatically controlled cuvette holder for 10 mm square cuvettes. Includes sufficient insulation to allow use over a wide temperature range (-10°C to 90°C). When used in conjunction with thermometer, bath, silicone fluid, and adequate insulation, the bath temperature and sample temperature are identical to within 0.1°C

HP temperature station (6040027000) HP model 89100A, Thermoelectric Temperature Controller. HP model 89101A, Temperature Station. HP model 89102A, Auxiliary Temperature Probe. NIGPIB-PC2A interface and 2 m cable. (Station includes built-in magnetic stirrer.) Requires system software and accessories option.

HP system software and accessories (6040029000), including: Light tight water system for extended temperature operation of the HP temperature station. Temperature station mounting adapter. Special HP version of instrument software.

Lapped and gold plated brass spacers for 1, 2 and 5 mm rectangular cells, for use in HP temperature station. (6040028000)

1.5.2 Advanced Data System Accessories

Solid sample holder for thin film studies (6040226000). Holds film from .025 mm to 1 mm thick. Aperture is adjustable from 1 mm to 13 mm diameter.

System to allow correction for highly scattering samples (6050002000). Reference A.S.Schneider and D.Harmatz, Biochemistry, Vol 15 pp 4158-4162, 1976.

Stopped flow CD system (6240326000). Uses BioLogic SFM-3 stopped flow mixing system and version of BioLogic Bio-kine software especially modified for SFCD. Includes sample compartment modifications, hardware for mounting SFM-3, program selected hardware time constants, variable gain settings and a second computer. Second computer control all instrumental parts of experiment: SFM-3 unit, CD unit and does fast data collection.

FDCD system (6040426000). Uses 2 inch red sensitive PMT in masked 90° mount, with emission cut-off filter, made of non-fluorescent glass.

1.5.3 Plotters

Two different plotters are offered

8 pen, digital, XY plotter, uses serial interface, with cable. HP ColorPro (0903000001)

high speed 8 pen, digital, XY plotter, uses serial interface, with cable. HP 7550a (0903000003)

1.5.4 Miscellaneous Accessories

Extended warranty (6200010000): Extension of original warranty for an additional year, includes all parts and labor except consumable items (e.g. Xe lamp, nitrogen)

Brass spacers, black finished (6040023000) to allow use of 1, 2, and 5 mm cuvettes in 10 mm holders.

Variable speed magnetic stirrer for square cuvettes. (6040024001)

Sample compartment cover with modified Hamilton repeating dispenser (6040025000), holds syringes from 25 ul to 2.5 ml, delivers 1/50 of capacity per press.

Red sensitive PMT (6050001000) to extend wavelength range to 800 nm, includes pre-amp, in Delrin housing.

Spare Xenon lamps: Two types depending on wavelength range used.

XBO 450W/4 Suprasil, for 175-800 nm. (0801000102) and XBO 450 Quartz, for 200-800 nm. (0801000103)

Calibration check cells (6041260000) for periodic instrument tests:

1. 10.0 cm benzene vapor cell for wavelength.
2. 1.0 cm CSA cell for full scale calibration.
3. 0.1 cm CSA cell for 2 point check.

water filter system

Nitrogen regulator (6060010000): Oil free, 2 stage, nitrogen purge gas pressure regulator and adjustable flow meter, fits standard gas cylinders and liquid vaporizers. (Instrument requires 20-30 standard cubic feet per hour of nitrogen gas, either pre-purified grade or liquid derived.)

Table 2 Specifications for 62DS

Light Source:	450 watt Suprasil Xenon Lamp
Monochromator:	Double Fused Silica Prism
Wavelength Range:	monochromator 175 nm to 800 nm
Stray Light:	less than 0.001% at 200 nm. less than 0.100% over operating limits
Wavelength Accuracy:	175 nm to 300 nm: ± 0.3 nm 300 nm to 500 nm: ± 0.5 nm 500 nm to 600 nm: ± 1.0 nm 600 nm to 800 nm: ± 2.0 nm
Wavelength Repeatability:	175 nm to 300 nm: ± 0.05 nm 300 nm to 500 nm: ± 0.10 nm 600 nm to 800 nm: ± 0.20 nm
Wavelength Resolution:	200 nm ± 0.03 nm 350 nm ± 0.05 nm 500 nm ± 0.20 nm 600 nm ± 0.40 nm 700 nm ± 3.50 nm
Photo multiplier tube:	High performance end on standard PMT 175 nm to 600 nm Red enhanced PMT to 800 nm
Baseline Stability:	Less than ± 0.5 mdeg per hour drift after 30 minute warm-up.
Sensitivity:	0.1 millidegree on ± 500 millidegree full range.
RMS noise:	At 1.0 nm bandwidth, no sample, with a 4 second time constant. Less than: 0.25 mdeg at 185 nm 0.15 mdeg at 200 nm 0.06 mdeg at 500 nm.

Section 2 Installation

This Section deals with getting up your CD spectrometer setup and operating.

2.1 Installation requirements

To operate the AVIV Circular Dichroism Instrument several service utilities need to be available and ready for use before installation. The major concerns are electricity for powering the instrument, water of cooling, and nitrogen to purge the optical system.

2.1.1 Electrical Power Requirements

The instrument requires a dedicated electrical circuit, which depends on the country of installation: U.S.A.: 115 volt, 50/60 Hz AC, 30 Amp, single phase. Hubble receptacle #2610A; European: 220 volt, 50/60 Hz AC, 15 Amp, single phase. The connector varies, depending on country. Table 3 provides the amount of current required by various instrument - option combinations.

2.1.2 Environmental Requirements

The spectrometer should be housed in a location moderately ventilated, free of dust and excessive mechanical vibrations. The CD spectrometer can operate in the range between 15 and 30°C. As the instrument is a moderate heat source, it is often desirable to determine if there is adequate room temperature control. It is possible to calculate the heat output of the instrument.

To convert power in Watts to BTU/Hr.

To calculate the power:

1. Add up total Amps for Instrument and any installed options.
2. Watts = Amps x Volts

Convert to BTU/Hr using these conversions:

$$\text{BTU/min} = \text{Watts} \times 0.05688$$

$$\text{BTU/Hr} = \text{BTU/min} \times 60 \text{ Min/Hr}$$

Table 3 Current in Amps used by Instrument and Options

Model Number	60DS	61DS	62DS	
		115 volts 50/60 Hz		220 volts 50/60 Hz
Instrument ^a	20.5	20.5	16.5	8.25
Options:				
bath (Lauda) ^b	13.0	13.0	13.0	6.5
plotter (HP)	2.0	2.0	2.0	1.0
Stopped Flow & 2nd computer	7.6	7.6	7.6	3.8
HP temp unit	1.0	1.0	1.0	0.5

^aThe instrument includes: CPU, Monitor, Keyboard, Printer, and internal instrument power.

^bThe bath requires a separate electrical circuit. All other options can operate on the instrument circuit.

2.1.3 Instrument Water Requirements

The instruments require a continuous supply of tap water to be available while the Xe lamp is on. This water is used to dissipate the heat generated by the Xe lamp. It is recommended that the water be filtered to remove sediments that might clog up the internal plumbing. The water should be regulated to about 20 psi, with a maximum pressure of 60 psi. The connection to the instrument is by 5/16" I.D. high pressure hose. A combination filter/regulator system is available as AVIV option # 6060000000. The flow rate depends on the temperature of the water. For the 62DS a continuous flow rate of about 1 gal/min and a temperature less than 25°C are required. A drain, able to accept continuous water flow at the maximum flow rate is required for all systems.

2.1.4 Instrument Nitrogen Requirements

The instrument requires a continuous supply of nitrogen to be available while the Xe lamp is on. The nitrogen needs to be pressure regulated and flow controlled. A flow rate of 15-20 SCFH is required for normal instrument operation. Far UltraViolet operation (below 200 nm) requires 30 to 60 SCFH. Model 62DS has a set of flowmeters built into the instrument, which divides the Nitrogen internally. A nitrogen regulator with adjustable flowmeter is available as AVIV option #

6060010000. The instruments have fittings for 1/4" I.D. clear Tygon tubing. Two different systems are acceptable nitrogen sources.

Pre-Purified, Dry Nitrogen (tank color code TAN) water pumped.

Liquid Nitrogen type GP45 with Vaporizer or pressure building system.

2.2 Instrument Dimensions and utility layout

The size of the Model 62DS and the position of the connections for electricity, water and nitrogen is shown in Figure 2. The dashed line represents a suggested clearance region around the instrument for safe efficient operation.

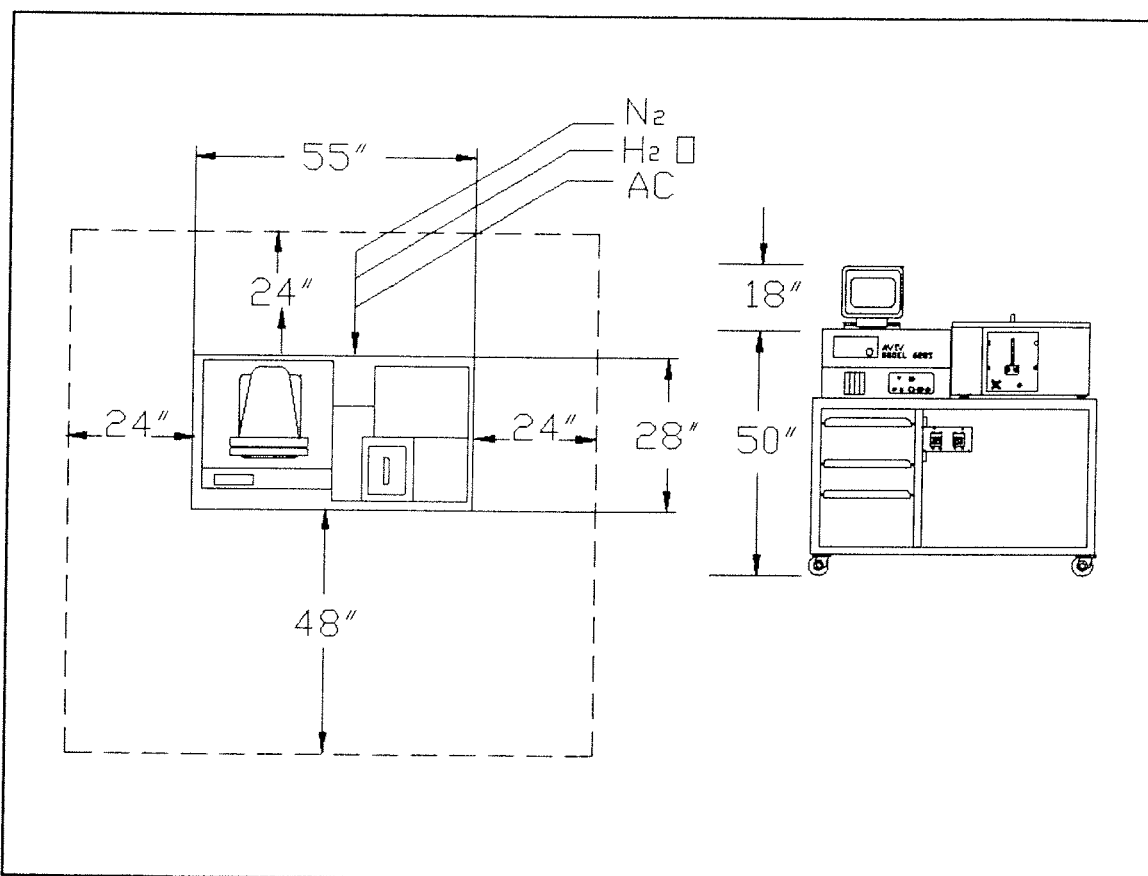

Figure 2 Instrument Dimensions and Utility Layout

2.3 Installation and Setup

2.3.1 Instrument

The initial installation and setup of the instrument is included in the purchase price of the instrument. The optical components in the polarizer compartment are removed and packed and shipped separately. The Xe lamp is packed in the original packing from the manufacturer. The external power supply and any options are packed in their own cartons.

2.3.2 Computer and peripherals

The computer, monitor, keyboard and printer are each packed in their own carton as provided by the manufacturer. Instructions for packing and setup are included in the computer User's manual. The cartons for the computer components should be retained, in the event that the component must be returned to AVIV for service.

2.3.3 Software Installation

Included with the master copies of the Instrument program, is a disk labeled Setup. This disk contains a series of batch files to reload the operating system, instrument programs and ancillary programs onto the harddisk of the computer. A similar disk is provided with each software update, making the process of upgrading your instrument software easier.

Section 3 Instrument Operation

3.1 System Startup

When the operator is ready to startup the instrument, the operator should follow these steps. Purge with Nitrogen for 15 - 30 minutes. Turn on water cooling system. Turn on breaker for Xenon Lamp Power supply. After several minutes the LAMP READY indicator will glow (yellow LED on the instrument control panel). This indicates that the power supply has sufficient power stored to strike the lamp. To fire the lamp push the red Button marked PUSH TO START on the control panel. Turn on the computer and instrument using the breaker marked COMPUTER. Start the instrument program by answering Y to the prompts on the computer.

3.2 Normal Operation

The instrument should be turned on at least 30 minutes prior to use. This allows time for the Xe lamp to stabilize, and the instrument to reach operating temperature.

If the supply of nitrogen to the instrument is disconnected the Nitrogen Alarm will sound and the red LED marked N₂ LOSS will glow. The alarm will sound for about 90 seconds before the instrument will turn off the lamp. This is to protect the instrument and operator from the hazards of using the Xe lamp without nitrogen.

While the lamp is on the bar graph along the top of the control panel marked LAMP CURRENT will glow. The number of red panels indicates the current (in amps) supplied to the lamp. The range is 18 to 27 amps, with each bar representing one amp.

The temperature of the Xe lamp is monitored, and if a set point is exceeded the instrument will turn off the lamp. The glowing red LED marked LAMP TEMPERATURE indicates the lamp has overheated. The internal temperature of the Xe lamp power supply is also monitored. If the power supply overheats the red LED marked HEAT SINK TEMPERATURE will glow and turn off the lamp.

The time that the Xe lamp is turned on is recorded on the meter marked LAMP HOURS on the instrument control panel. The Xe arc lamps have a limited lifetime and over this lifetime both the intensity and stability will change. The intensity of

the Xe lamp is highest when new. The intensity decreases gradually as the lamp ages. The stability of a Xe lamp is maximum after about 20 hours of use. The stability then decreases gradually until about 1000 hours, after which the stability may change abruptly. After 1500 hours of use, any lamp is an extreme safety hazard and should be treated as such. Lamp energy in the Far UV (below 200) is more sensitive to lamp age than operation in the regular UV or visible. Lamp life under extreme conditions can be as short as a few hundred hours. For example, excessive striking of the lamp will greatly shorten its useful life.

3.3 System Shutdown

When the operator is ready to shut down the instrument, the operator should follow these steps. Save or delete all data from computer memory. Execute the file EXIT (**Alt F1** then at prompt type EXIT). This will cause the Instrument program to move the monochromator near home wavelength and quit. If unsaved data remains EXIT will fail. This gives you a second chance to save any files. Type **Ctrl D** to quit and respond to the prompt with Y. Turn off lamp, and computer power switches. Turn off the water cooling system. Turn off Nitrogen purge 2-5 minutes after lamp.

Section 4 Sample Handling

4.1 Sample compartment

The sample compartment cover is located on the top front right of the instrument. In the sample compartment is a V block on a dynamic mount that is designed to support 22 mm O.D. cylindrical cells and short path cells with 22 mm O.D. and 16 mm I.D.. The V block will accept a holder for 1 cm rectangular cells. The PMT operating level servo lowers the high voltage on the dynodes in response to the increased light when the compartment is open, and protects the PMT from excess current.

4.2 Cells in the CD

The best cells to use in the CD should be strain-free and made of fused silica. Suitable cells are available from AVIV and from other commercial sources (Helma, Precision). Cylindrical cells have traditionally been employed in CD, because they were less likely to show residual strain in the form of linear dichroism. However, any cell tested to be free of linear dichroism can be used successfully.

Cells can be tested by comparing the cell baseline to the instrument air baseline. Significant deviations between these two (more than 10 millidegrees) should rule out a cell. The cell baseline should show no peaks (either positive or negative). The cell baseline should be taken in both orientations and should be relatively orientation independent.

Cells are available commercially in path lengths from 0.001 cm to 20.00 cm. The 0.001 cm cell is in two parts for easy cleaning. Long path length cells (>2 cm) should be used only when absolutely required, due to the possibility of artifacts caused by scattering.

Rectangular cells less than 1 cm should have spacers to provide accurate positioning in the holder.

4.3 Using cylindrical cells

The large window of the cell should face the light entrance. Position cell neck in

notch. The cell should have a stopper in place and the neck should be placed in the notch on the sample holder to control position for repeatable results.

Cells from 0.1 mm to 5.0 mm have a concavity of 16 mm I.D. to reduce the path length. Cell volume is about ?ml. 10mm and 20mm cells are plain cylinders of 22mm O.D.. Cell volumes are about ?ml and ?ml.

4.4 Sample preparation

Samples should be homogeneous and filtered if necessary to remove particulate matter which can cause errors due to light scattering.

4.4.1 Optimizing Conditions

The best CD signal to noise ratio is obtained in a shot noise limited system at a sample absorbance of 0.868 abs (13.6% transmission). The recommended range is .5 to 1.5 abs (32% to 3% transmission). Higher absorbance will cause longer scanning times as the system attempts to compensate for the increased noise. As a rule of thumb a dynode voltage above about 900 volts indicates an impossibly noisy signal. Absorbance due to non-optically active components should be minimized. Water absorbs about 1 abs at 182 nm in a 0.1 cm cell, and about 1 abs at 176 nm in a 0.005 cm cell. Buffers, salts, and all organic molecules can potentially contribute to absorbance.

4.4.2 Use the same cell for the baseline

Since some strain in the cell is unavoidable, you will get the best baseline values if the baseline is taken with the same cell used for the sample.

4.5 Care and cleaning of cells

Cells should not be touched on the optical windows. Highly alkaline solutions should not be left in them for extended periods. A cell should be rinsed and soaked in distilled water immediately after use. Clean with a mild detergent solution containing no lanolin, oils, or other contaminants. Proteins may be removed with a mixture of equal parts of 3 N HCl solution and 50% ethanol. Overnight soaking in a mild pepsin solution may be helpful at times. After cleaning, cells should be rinsed in distilled water and gently blown dry with clean, dry air or nitrogen.

4.6 Temperature Control

This is a description of the bath temperature control system and an introduction to its use. The description of the temperature control process does not apply to the HP thermoelectric sample holder for the 60 DS.

Temperature is measured to a precision better than 0.05 °C. Temperature can be specified to 0.1 °C over the range of -30 to +100 °C. We specify the system to work over -10 to +90 °C. We are interested in knowing better what temperature range and precision users will actually need in their work.

The overall operation of the temperature setting system is as follows. The computer generates a number specifying a setpoint temperature for the bath. The computer then communicates this setpoint to the bath by generating a voltage proportional to the desired temperature. (The bath converts this voltage to a number for display as an alternate to the temperature it senses.) The bath control also generates locally a voltage proportional to the temperature in the bath. The bath control makes the two voltages match. The computer does not read the temperature voltage which the bath generates, but reads temperature using its own sensor, which may not be in the bath, but rather is usually in a place with a temperature closer to the sample temperature, or even in the sample. We use this ability to set the bath temperature and monitor the result at our sensor to insure that the sample is at a known, stable temperature before each data point is taken.

We must cope with a non-ideal temperature control mechanism. The complete system includes several places where measurement inconsistencies can occur. Temperature errors can result from the digital to analog to digital control and measurement system. There can be inherent discrepancies between the temperature measured by the bath and the temperature measured by the computer due to the use of different kinds of sensors. Temperature measurement at the cell will also be affected by heat gains or losses between the cell and the bath. The system must therefore cope with the situation that the temperature is stable but not identical with the requested temperature.

The solution we have adopted to the control problem is to say that the bath has finished responding to a setpoint change when the sensed temperature is stable and reasonably near the temperature asked for. The detailed mechanism involved in making this decision is explained below in case you need to adjust any of its parameters to improve operation in a particular circumstance. Much of the time, however, the default parameters will suffice.

Sensor

The temperature sensor we use is a semiconductor type, which is inherently linear. We currently have good precision in measurement. Accuracy is always a problem in temperature measurement however, and we recommend that the sensor be checked and recalibrated if necessary against a reference mercury thermometer periodically. (See the separate note on calibration.)

The sensor by itself is specified by its manufacturer over a range of -55 °C to +150 °C. Our instrument circuit can record over a range of -100 C to +100 °C. The result

is a useable range of -55 to +100 °C. The sensor is not specifically characterized over our temperature range, but the worst case nonlinearity over its full range is specified as ± 0.4 °C.

Repeatability and long term drift are each specified as ± 0.1 °C. The worst nonlinearity errors occur at the ends of the range. After a two point calibration the total measurement error should be no worse than ± 0.2 °C over our specified range of -10 to +90 °C.

Section 5 Maintenance

5.1 Introduction

Your AVIV spectrometer has been designed to be generally trouble free. However, certain simple tests should be periodically performed to insure that the instrument is operating properly. Wavelength calibration is tested using Benzene vapor. The CD signal is tested using a stable organic molecule with known CD properties (CSA). Energy measurements and noise tests can help identify lamp aging and other instrument problems. These tests should be performed at least once every 300 hours of instrument use.

This section also covers testing and calibrating baths and thermometers, Xe Lamp changing and other simple maintenance.

5.2 Instrument Calibration Procedures

5.2.1 Wavelength Calibration

The gas phase spectra are useful in calibrating the Home wavelength of the monochromator. The wavelength drive is very precise and coupled with the very narrow benzene peaks gives a accurate determination of the home wavelength.

This calibration procedure required about a drop of benzene in a 10.0 cm quartz cylindrical cell. The Benzene vapor should have an absorbance of about xx at yyy nm.

In wavelength mode, collect in Dynode voltage (Alt F8), the following :

SCAN 268 to 266 every 0.02 nm with 0.04 nm BW AvT 0.2 sec

266.71	nm
- _____	nm
_____	nm difference

Adjust Home Wavelength (CTRL F1)

- a. if the difference is negative (peak above 266.70 e.g. 270) then the difference should be subtracted from the home wavelength
- b. if the difference is positive (peak below 266.70 e.g. 260) then the difference should be added to the home wavelength

home wavelength	_____
Difference x 100	_____
New Home Wavelength	_____

If the home wavelength needs to be adjusted be sure to update the file C:\avi\wavecal.avi. You can either edit the file or use the utility program, INST-CAL.EXE. Use this program to update any of the information in wavecal.avi. Run INST-CAL.EXE by typing INST-CAL at the DOS prompt.

5.2.2 CSA checks

CSA, (1S)-(+)-10-Camphorsulfonic Acid, is used to test the calibration of the CD detection system in your instrument. Two types of tests are conducted, absolute calibration of CD signal intensity and linearity of the CD signal. To test the absolute CD calibration a solution of CSA of known concentration must first be prepared.

5.2.2.1 Calibration of CSA

OBJECTIVE: Use an Absorbance measurement to standardize a CSA Solution. By using Beer's Law, it is possible to calculate the product of CSA Concentration and cell pathlength. This product can be used to calculate the ellipticity of the sample.

SPECIFICATION: Absorbance known to 4 significant figures

MATERIALS: highest purity of (1S)-(+)-10-Camphorsulfonic Acid (CSA) at a concentration about 1.0 mg/ml in water
1.0 cm quartz cell (either cylindrical or rectangular)

CONDITIONS: wavelength scan from 320 to 240 nm, 1 nm BW, 0.5 AvT,
0.2 nm step on a reliable spectrophotometer

PROCEDURE:

1. Set up Absorbance instrument
2. Run water baseline of cell,
3. Remove water from cell, and rinse 3 to 4 times with CSA solution
4. Run spectrum of CSA solution and rename as CSA-ABS
5. At 320 nm baseline and CSA-ABS should have same value
6. Correct Spectrum and Save

4. Add baseline and sample value

Base + Sample 290 _____

5. Compare to value calculated in CSA Calibration

Calculated 290 _____

6. If required adjust DC gain to value calculated

5.2.2.3 CSA PEAK RATIO TEST

SPEC: Ratio of 290 to 192.5 nm peaks should be between 1.9 to 2.2

MATERIALS: 0.1 cm path length cell with CSA 1 mg/ml

CONDITIONS: 320 nm to 180 nm 0.5 nm step 1.5 nm bandwidth, AvT 0.2

PROCEDURE:

1. Collect Spectrum of CSA, rename CSA
2. Collect an Air baseline, rename CSABASE
3. Assign as baseline (alt-b) and correct CSA
4. Find values of peaks near 290 and 192.5 nm.

192.5 _____nm	CD _____ mdeg
290 _____nm	CD _____ mdeg

5. Calculate Ratio

CD at 192.5 / CD at 290 _____

6. Save files on data disk (CSA, CSABASE, CSA.ACD). add note to CSA.ACD about ratio

5.2.3 Energy tests

SPEC:

MATERIALS:

CONDITIONS: with polarizer & modulator and high N2 purge (50 SCFH)

1. Record Hours on lamp _____
2. Record dynode voltage at 1.5 nm BW
3. Perform Energy test (Alt-F9), record slit width at 500 volts

	DYNODE VOLT	SLIT WIDTH
800	_____	_____
700	_____	_____
600	_____	_____
500	_____	_____
400	_____	_____
300	_____	_____
250	_____	_____
225	_____	_____
200	_____	_____
190	_____	_____
187.5	_____	_____
185	_____	_____
180	_____	_____
179	_____	_____
178	_____	_____
177	_____	_____
176	_____	_____
175	_____	_____

5.2.4 Noise

SPEC: noise at 1 nm BW no sample and 4 second TC

500 nm 0.06 md
 200 nm 0.2 md
 185 nm 0.3 md

MATERIALS:

CONDITIONS: test with polarizer and modulator with high N2 purge (50 SCFH)
 noise test 1 nm BW for 10 min

CONDITIONS: 500 nm, 0 Abs, 1 nm bw, AvT 1 sec, 1 sec step, for 10 min.

PROCEDURE:

1. Go to specified wavelength
2. Record scan as outlined above
3. Save as 500NOISE for 500 nm (etc.)
4. Record Peak to Peak Noise (USE CTL HOME TO GET VALUES)
5. Record RMS Noise (USE ALT 2 TO GET VALUE)

Wave	AvT	RMS	High	Low	Difference
500	4	_____	_____	_____	_____
200	4	_____	_____	_____	_____
185	4	_____	_____	_____	_____
180	4	_____	_____	_____	_____
178	8	_____	_____	_____	_____
175	8	_____	_____	_____	_____

5.3 Error Flags and problems

5.4 Lamp Changing

5.4.1 Warnings and Precautions when changing Xenon Lamp

Extreme care should be exercised in changing the Xenon Arc lamp in the 60 series CD. The lamp is a source of several different types of hazards: explosion, eye damage from radiation, burn hazard, electrical hazard.

When handling a Xenon Arc lamp use a full face shield, and wear protective gloves.

The Xe lamp is under pressure and is has the potential of exploding. At room temp the Lamp is under about 8 atmospheres of pressure. However, under operating conditions the pressure is about 25 atmospheres. The Xenon lamp is shipped from the lamp manufacturer in a plastic cover. This should be placed on the lamp whenever possible. This plastic cover will provide good protection against damage from explosion when locked in place around the lamp.

Do not operate the Xe Lamp with the cover off of the lamp compartment. The lamp produces ozone from the oxygen in the air. Ozone is harmful to humans and will attack the optical surfaces inside the instrument.

Do not look directly at an operating Xenon lamp. The lamps used in the CD have very intense radiation in the UV, Visible, and Near IR. This radiation can cause blindness, UV damage and "sun burn". Care should be used to minimize the exposure to the radiation.

The inside of the lamp house has both high voltages and high currents during the normal operation of the lamp. The large cable going into the bottom of the lamp house should be unplugged before working inside. The Lamp breaker should also be turned off.

After the lamp has been on, it is very hot. After turning the lamp off, the lamp will glow red for several minutes. To insure it is safe to handle the lamp wait 15-20 minutes after turning off before handling. This allows time for the lamp to cool, as well as time for the capacitors in the system to discharge.

5.4.2 Lamp removal

Turn power off, unplug large connector at bottom of lamp compartment. Allow 15-20 minutes for system to cool if the lamp has been turned on. Turn nitrogen purge and cooling water off. Locate protective case for lamp. Remove top screws in lamp

compartment. When cover is removed do not touch any optical surfaces inside the compartment.

Remove the lamp heat sink from the top of the lamp (anode) by loosening the thumb screw. Place the heat sink on the shipping post.

Carefully remove the top of lamp from the spring mounting hardware. Then gently lift the lamp from the base connections. Promptly place the protective cover over the lamp and lock the cover in position.

5.4.3 Lamp and compartment Inspection

New lamps should be inspected for obvious manufacturing defects before installation, such as cracks, etc. The length of the lamp is critical see figure.

The inside of the lamp compartment should also be inspected for signs of degradation. Burnt wires or charred contacts represent potential problems. Report anything suspicious looking to AVIV for assistance.

5.4.4 Lamp Installation

Carefully remove lamp from cover. Inspect lamp for foreign matter. If needed gently dust off.

Insert Lamp into base anode (+) end up. Make sure lamp is firmly seated in base. The lower spring contacts should grip the lower electrode. Position the upper electrode into the anode holding mechanism. The lamp should be securely held in place in the lamp carriage. Rotate the fill tube on the lamp toward the rear of the lamp carriage, away from the ellipsoidal mirror. Remove the heat sink from the shipping post and carefully place on the anode of the lamp and tighten the thumb screw.

Replace the lamp compartment cover. Make sure that all screws are tight and in position. The cover must be tight to insure against light and Nitrogen leaks.

Note time on lamp elapsed time meter and date. This information is useful in determining instrument performance.

5.4.5 Lamp optimization

(needs figure showing locations of adjustments)

Three alignment screws on back of lamp compartment. Lateral, vertical and tilt Adjust lamp at 546 nm, or some other convenient wavelength.

Use ALT F9 (energy mode) which adjusts slits to give 500 volts on the DV. This is to make the measurement in the most sensitive range of the instrument. Middle of A/D converter range. Toggle off when settled about 500 volt.

Adjust position of lamp to give lowest DV possible. Adjust knobs in a specific order, adjust lateral then vertical, then tilt. Repeat the sequence until lamp is optimized.

If DV drops below 400 volts then use ALT F9 to reach 500 v again.

5.5 Calibrating options

Both the thermometer and the bath control can be calibrated in the field as necessary. This section tells where to find the calibration adjustments and gives a calibration procedure for each.

The calibration adjustment potentiometers are located on a circuit board marked "Aviv 60 offset board" on the rear electronics panel of the 62DS. Access to the electronics panel is by turning the quarter turn fasteners on the upper edge of the panel. The panel is then lowered on hinges. The accompanying diagram shows the board cover with all Labels and connectors. The thermometer pots are mounted on a plug in header on the board, and the bath pots are in a row along one edge. A small screwdriver is needed to turn the adjustment screws. Follow the adjustment sequences given below.

5.5.1 Thermometer Calibration.

Calibration of the thermometer should be performed periodically. Depending on accuracy requirements, perhaps as often as once a month. The sensor is linear, so there are just two independent adjustments possible. We use a zero intercept (TZ) and a slope (TS) adjustment.

Calibration requires an accurate reference thermometer and two stable temperatures. There is one adjustment to be made at each temperature. The adjustments must be made in order. The calibration zero point was chosen to be 0°C, the ice point, for simplicity. Any other temperature can be used for the gain adjustment. The other temperature should be far from the zero point. We use 50°C because this is near the other end of our reference thermometer and gives a range that covers most temperatures of interest.

An easy way to monitor the adjustment process is to record temperature in kinetics mode. You can easily see the effect of each adjustment and can easily tell when the effect of a change is complete. **Shift F4** turns on temperature recording. **Alt K** in setup selects kinetics mode. **Alt F10** starts the recording. **PAGE DOWN** rolls the temperature record back on the screen. **RIGHT** allows extension of the recording time. **LEFT** allows you to trim off the old parts of the record. **UP** and **DOWN** let

you set the vertical scale. **HOME** redraws the screen after making changes. You can easily plot several minutes of measurements second by second on a scale of only .2 degrees.

The thermometer calibration controls are mounted on a small, plug in header at U1 on the offset board, which is in the lower right. Adjust zero (TZ) first. Place the thermometer and the reference thermometer in an ice bath and let them equilibrate. At zero degrees the gain adjustment has no effect, so the zero adjustment is independent of the gain. Adjust TZ so that the computer reading matches the reference thermometer.

Once the zero point is set the two thermometers should be moved to the other temperature and equilibrated. Adjust only the thermometer gain calibration, TS, at this temperature. TS is also mounted at U1. Adjust the gain so that the computer reading matches the reference thermometer.

5.5.2 Bath Calibration

The bath calibration is less critical than the thermometer calibration. The object is simply to make the bath and the computer agree on the setpoint value to within a tenth of a degree or so. It may be done as necessary. The bath shows a small heating effect in its display of the setpoint, so the results of this calibration may vary depending on the bath temperature.

The bath setpoint drive circuit includes 3 adjustments, but only 2 of them are used. The third pot should only be adjusted once in the factory. As with the thermometer, we have a linear circuit with a zero and a slope adjustment. The zero point is the lower temperature limit. The slope adjustment is made at any convenient high temperature, and may be checked at several setpoints to arrive at a best setting for the circumstances of use.

The calibration is quick, and the bath will have time to change only a small amount during the process, so the system temperature will not have to be much disturbed. Make sure the computer is connected and the bath is in remote control mode. Adjust only one pot at each temperature and perform the adjustments in order, first zero and then gain.

To adjust the bath setpoint zero, use Shift F1 to set the setpoint in the computer to -30°C. The setpoint will be displayed if temperature control mode is on. Turn on temperature control with Shift F3. With the computer calling for -30°C, the value sensed by the bath can be displayed by holding in the button on the bath near the display. Adjust BZ (P2), to make the bath setpoint display read -30°C.

Once the zero point is set, use Shift F1 again to change the computer setpoint to some other temperature, say 50°C. Display the bath setpoint value again and adjust

BS (P3). Make the bath display match the computer setpoint.

You can use Shift F1 again to check the bath reading at other temperatures of interest and to finally return the bath setpoint to the place you want it to stay.

Please note that the bath's temperature sensor is not linear and will produce a small error compared to the reference thermometer, particularly near 50°C, even though the setpoint is calibrated properly.

6 Appendix

Manual Version - _____ Revision Date _____

INSTRUMENT:

Model Number _____ Serial Number _____
Software Version _____ Problem Date _____

REPORTER:

Name _____
Address _____
City _____ State _____ Zip _____
Country _____ Phone (____) - _____

INSTRUCTIONS:

Use this form to report software bugs, documentation errors, instrument problems or general suggestions. Please mail this form to AVIV or fill out and keep available while reporting the problem using another communication method.

PROBLEM CATEGORY:

Software Problem Documentation Problem
 Instrument Problem Other _____

PROBLEM DESCRIPTION:

Describe the problem giving as much detail as possible. If possible, describe how to reproduce the problem, and any suggested corrections. Use as many pages as necessary to fully explain the problem. Attach a listing or a screen dump as applicable. Log files are especially useful.

Mail form to: _____ or _____
AVIV Associates, Inc. Phone: 908-367-1663
750 Vassar Ave Fax: 908-370-0032
Lakewood, NJ 08701, USA